

2012



Rule Book

www.mstpapulling.com

2012 PULLING SCHEDULE

<u>DATE</u>	<u>LOCATION</u>
May 5	Sedalia, MO – Play Day
May 26	Cole Camp, MO
June 1	Russellville , MO
June 2	Sedalia, MO Dream Factory
June 16	Peculiar, MO
June 23	Garden City, MO
July 7	Garnett, KS
July 14	Clinton, MO
July 21	Fort Scott, KS
July 22	Pleasant Hill, MO
July 27	Emporia, KS
July 28	McLouth, KS
July 31	Jefferson City, MO
August 3	Springfield, MO
August 4	Springfield, MO
August 11	Lockwood, MO
August 12	Missouri State Fair
August 13	Missouri State Fair
August 18	Oak Grove, MO
August 25	El Dorado Springs, MO
August 26	LeRoy, KS
August 31	Louisburg, KS
September 1	Louisburg, KS
September 8	Sedalia, MO
September 22	Archie, MO

**** This is a tentative schedule
and is subject to change!!!! ****

TABLE OF CONTENTS

Board of Directors & Officers	1
Bylaws	2
Committees	4
Identification of Pulling Vehicles	5
MSTPA Sanctioned Pulls	6
General Rules	10
General Sled Rules	17
Protest Rules	18
General Vehicle Rules	20
5900 Profield Tractors	23
9000 Profield Tractor	25
9500 Limited Prostock Tractors	27
6200 Prostock Tractors	29
6000 Superstock Tractors	32
5900 & 7400 Modified Tractors	35
6200 Two-Wheel Drive Truck	39
6200 Prostreet 4x4 Truck	42
6200 Prostock 4x4 Truck	45
8000 Diesel 4x4 Truck	48
Open	52
Drawbar Rules	50
Illustrations	52

BOARD OF DIRECTORS AND OFFICERS

Mike McCoy, President

602 Jackson Ave
Archie, MO 64725
816-392-6166
Term: Dec. 2012 – Dec. 2015

Jere Setter, Vice President

240 E 5th St
Garnett, KS 66032
785-448-3968 or 785-448-2100
Term: Dec. 2009 – Dec. 2012

Melissa Cumpston, Treasurer/Secretary

7414 Tanner Bridge Rd
Jefferson City, MO 65101
816-738-9624
mcumpston@mstapulling.com
Term: Dec. 2012

Kit Carter

13698 Highway B
Green Ridge, MO 65332
660-527-3647 or 660-620-2969
Term: Dec. 2011 – Dec. 2014

Max Swisegood

9511 S. Outer Belt Road
Oak Grove, MO 64075
816-690-4481 or 816-935-3795
Term: Dec. 2011 – Dec. 2014

Marc Bayne

16161 Hwy E
Lexington, MO 64067
660-909-3404
Term: Dec. 2011 – Dec. 2014

Danny Brockhaus

1013 NW 250
Holden, MO 64040
816-215-9177
Term: Dec. 2010 – Dec. 2013

Larry Greene

458 SW 2 Highway
Chilhowee, MO 64733
660-909-8982
Term: Dec. 2006 – Dec. 2012

Mike Kohler

28611 E. Highway Z
Harrisonville, MO 64701
816-679-4947
Term: Dec. 2009 – Dec. 2012

Jason McCoy

8824 Stillhouse Rd
Liberty, MO 64068
816-255-5810
Term: Dec. 2009 – Dec. 2012

Dennis Lancaster

18005 E. 227th St.
Harrisonville, MO 64701
816-509-8264
Term: Dec. 2010 – Dec. 2013

Austin Ritter

23199 Hwy AA
Higginsville, MO 64037
660-238-7628
Term: Dec. 2010 – Dec. 2013

Alan Murray

10635 NW Center Rd
Lowry City, MO 64763
660-492-3526
Term: Dec. 2010 – Dec. 2013

BYLAWS

Missouri State Tractor Pullers Association Amended February 14, 2006

NAME

The name of the organization shall be the Missouri State Tractor Pullers Association.

PURPOSE

The purpose of MSTPA is to promote the sport of tractor & truck pulling by providing standard rules and assistance to individuals interested in or participating in the sport of pulling as well as to individuals, groups and organizations wishing to conduct such contests.

MEMBERSHIP

The membership shall consist of individuals desiring to participate in the sport of pulling who have met the requirements of the Association as defined in the MSTPA Rule Book.

OFFICERS

The Association shall be governed by a Board of Directors consisting of 12 individuals. Four board members shall be elected each year by and form the membership & serve for a three-year term. Officers will be elected each year by the Board of Directors. They are the President, Vice President, Secretary, and Treasurer.

The board can fill any vacancy that may occur during the year. That person shall complete the term of the member they are replacing. The vacancy shall be filled with the member who received the most votes but was not elected to the board at the most recent general election.

MEETINGS

A Board of Directors meeting may be called at the President's discretion to direct the business of the Association & ensure its continuity and stability. The first 30 minutes of board meetings will be open forum. After that 30 minutes the board will go into closed session

An annual meeting will be held for the purpose of conducting the business of the Association. This includes, but is not limited to, the review of the previous year's business, review and modification of Association rules & election of board members. Time & location shall be at the discretion of the board.

AMENDMENT OF BYLAWS

These bylaws may be amended at any Annual Meeting of the MSTPA by a two-thirds vote, providing that the amendment has been submitted in writing prior to that Annual Meeting.

COMMITTEES

Competition Committee:

Jere Setter

Protest Committee:

Modified, Superstock & Prostock Tractor:

Max Swisegood

Alan Murray

Jason McCoy

Pickup Truck Classes:

Kit Carter

Danny Brockhaus

Dennis Lancaster

Marc Bayne

Profield & 9500 Prostock:

Austin Ritter

Mike Kohler

Larry Greene

Overseer:

Mike McCoy

Jere Setter

Announcer – Chad Buschjost and Ron Stone

100 ft. Flagman – board member

300 ft. Flagman – Eric Guthrie

Sign Ups – Melissa Cumpton and Diane Rector

IDENTIFICATION OF PULLING VEHICLES

5900 PROFIELD TRACTORS are agricultural tractors having stock appearing block, with one injection pump or one carburetor with water injection allowed. This class was originally known as "Out-of-the-Field" or "Hot Farm".

9000 PROFIELD TRACTORS are agricultural tractors with stock-appearing engine block. They may use "A" or "P" injection pump or stock-appearing pump.

9500 LIMITED PROSTOCK TRACTORS - 4.1 turbo charger at the inlet tractors, 640 cu. In..

6200 PROSTOCK TRACTORS are tractors using one (1) turbo, one (1) pump or carburetor, stock fuel for the make & model of the tractor and 24.5x32 max. tire size.

6000 SUPERSTOCK TRACTORS have a stock chassis or its replacement and stock rear end housing. ANY MODIFICATIONS MUST HAVE MSTPA BOARD APPROVAL. The criteria used by the board will be the retention of stock appearance and safety.

5900 & 7400 MODIFIED TRACTORS have any combination of engines, transmissions & final drives. Engines are limited to a max. of four (4) naturally aspirated or two (2) blown or single aircraft or single industrial engine. This class was formerly known as the "Hot Rod" class.

6200 TWO-WHEEL DRIVE TRUCKS may run any body style with a presentable bed or flat. Trucks newer than 1940 have hoods & fenders. No aluminum blocks.

PROSTREET, PROSTOCK, & DIESEL 4x4 TRUCKS have stock frame & body with securely fastened bed & fenders.

MSTPA – SANCTIONED PULLS

The individual or organization sponsoring a sanctioned pull will pay a sanctioning fee of seven-hundred dollars (\$700) which will provide:

- One-million dollars (\$1,000,000) per event of commercial racing liability insurance coverage
- Protected pull date
- Track officials
- Services of a board member to monitor the eligibility of all entrants, ensuring that rules are followed.

The sanctioning fee must be mailed to the Treasurer by April 15th.

An entry fee will be paid to the Secretary / Treasurer by each contestant at the time of entry or prior to hooking.

Prize money will be five-hundred dollars (\$500) for 5900 Profield Tractors, to be paid as follows:

- 1st place shall receive \$ 150.00
- 2nd place shall receive \$ 125.00
- 3rd place shall receive \$ 100.00
- 4th place shall receive \$ 75.00
- 5th place shall receive \$ 50.00

Prize money will be six-hundred dollars (\$600) for the 5900 Modified Tractors, to be paid as follows:

- 1st place shall receive \$ 180.00
- 2nd place shall receive \$ 150.00
- 3rd place shall receive \$ 120.00
- 4th place shall receive \$ 90.00
- 5th place shall receive \$ 60.00

Prize money will be six-hundred fifty dollars (\$850) for the 9000 Profield Tractors, to be paid as follows:

- 1st place shall receive \$ 220.00
- 2nd place shall receive \$ 185.00
- 3rd place shall receive \$ 155.00
- 4th place shall receive \$ 125.00
- 5th place shall receive \$ 90.00
- 6th place shall receive \$ 75.00

Prize money will be six-hundred fifty dollars (\$650) for the 6200 Prostock Tractors, to be paid as follows:

- 1st place shall receive \$ 195.00
- 2nd place shall receive \$ 160.00
- 3rd place shall receive \$ 130.00
- 4th place shall receive \$ 100.00
- 5th place shall receive \$ 65.00

Prize money will be seven-hundred fifty dollars (\$850) for the 6000 Superstock Tractors, to be paid as follows:

- 1st place shall receive \$ 245.00
- 2nd place shall receive \$ 200.00
- 3rd place shall receive \$ 170.00
- 4th place shall receive \$ 140.00
- 5th place shall receive \$ 95.00

Prize money will be nine-hundred dollars (\$900) for the 6200 Prostreet 4x4 Trucks, to be paid as follows:

- 1st place shall receive \$ 260.00
- 2nd place shall receive \$ 220.00
- 3rd place shall receive \$ 170.00
- 4th place shall receive \$ 120.00
- 5th place shall receive \$ 80.00
- 6th place shall receive \$ 50.00

Prize money will be one-thousand five hundred dollars (\$1500) for the 7400 Modified Tractors, to be paid as follows:

- 1st place shall receive \$ 420.00
- 2nd place shall receive \$ 350.00
- 3rd place shall receive \$ 280.00
- 4th place shall receive \$ 200.00
- 5th place shall receive \$ 150.00
- 6th place shall receive \$ 100.00

Prize money will be one-thousand two hundred dollars (\$1200) for the 6200 Two Wheel Drive Trucks, to be paid as follows:

- 1st place shall receive \$ 340.00
- 2nd place shall receive \$ 280.00
- 3rd place shall receive \$ 220.00
- 4th place shall receive \$ 170.00
- 5th place shall receive \$ 120.00
- 6th place shall receive \$ 70.00

Prize money will be two-thousand dollars (\$2000) for the 9500 Limited Prostock Tractors, to be paid as follows:

- 1st place shall receive \$ 550.00
- 2nd place shall receive \$ 450.00
- 3rd place shall receive \$ 400.00
- 4th place shall receive \$ 300.00
- 5th place shall receive \$ 200.00
- 6th place shall receive \$ 100.00

Prize money will be eight hundred dollars (\$800) for the 8000 Diesel 4x4 Trucks, to be paid as follows:

- 1st place shall receive \$ 235.00
- 2nd place shall receive \$ 185.00
- 3rd place shall receive \$ 155.00
- 4th place shall receive \$ 125.00
- 5th place shall receive \$ 100.00

Prize money will be one-thousand, two-hundred twenty-five dollars (\$1225) for the 6200 Prostock 4x4 Trucks, to be paid as follows:

- 1st place shall receive \$ 350.00
- 2nd place shall receive \$ 250.00
- 3rd place shall receive \$ 200.00
- 4th place shall receive \$ 150.00
- 5th place shall receive \$ 100.00
- 6th place shall receive \$ 75.00
- 7th place shall receive \$ 50.00
- 8th place shall receive \$ 50.00

Sponsors will:

- Allow two (2) free passes per pulling vehicle
- Provide a minimum of four (4) “pull-off” tractors to tow vehicles unable to operate under their own power
- Provide an ambulance in the pull area during the pull
- Provide a pulling track a minimum of 250 feet in length and 30 feet in width
- Maintain the pulling track by blading & packing throughout the pull.

Points for a sanctioned pull shall be awarded as follows:

1 st place	13 points	8 th place	6 points
2 nd place	12 points	9 th place	5 points
3 rd place	11 points	10 th place	4 points
4 th place	10 points	11 th place	3 points
5 th place	9 points	12 th place	2 points
6 th place	8 points	13 th place	1 points
7 th place	7 points		

In addition each member will receive 10 show up points and 3 hook points in addition to placing points. Show up points are only given if the show has started. If the show is cancelled prior to start no points will be awarded. If a class has started and gets rained out 13 points will be awarded to all members signed up in said class. If a class has started and cancelled for any reason, class purse will be disbursed equally with pullers entered.

An exception to the distribution of points will be made if a one-day hook puller places. When this happens, the point value of a place will increase by one point for all places below that of the one-day hook puller.

EXAMPLE: A one-day hook puller receives 3rd place. 1st place – 13 points; 2nd place – 12 points; 3rd place – 0 points; 4th place – 11 points; 5th place – 10 points etc. (4th place still receives 4th place prize money.)

All other vehicles hooking to the sled will get three (3) points.

GENERAL RULES

1. Membership dues will be one-hundred fifty dollars (\$150) prior to January 1st, 2012 from January 2nd until April 15th membership will be a fee of one-hundred seventy five dollars (\$175) after April 15th, 2012 the fee will increase to one-hundred seventy-five dollars (\$175). Each membership includes 1 vehicle. Each additional vehicle will be charged twenty-five dollars (\$25). All non-members can pay a fifty dollars (\$50) per day hook fee and will receive no points. An associate membership is available for twenty-five dollars (\$25) a year which allows a nonparticipating member to receive all advertisements & mailings.
2. There will be one (1) vote per pulling vehicle, per class with paid membership that pulled 40% of that said class during the current pulling season. All paid members can vote on General Rules. Absentee votes do not count.
3. All class rule changes must be submitted in writing to Jere Setter thirty (30) days prior to the annual meeting to be eligible to be voted on.
4. Pullers under 18 years of age must have a written consent of both parents or legal guardian. Contestants must be at least 16 years of age to participate in any class with the exception of a 3000 RPM limited class and that age limit is set at 15 years or older.
5. A sanctioned pull will use a dirt track not less than 250 feet in length and not less than 30 feet in width. This track will be maintained & packed with a box blade & roller during the pull.

6. A sanctioned pull will be governed by judges with all decisions final. Judges or board members have the right to stop and/or disqualify any contestant's vehicle that is being operated in an unsafe manner. Any violation of these rules will disqualify the driver & forfeit his/her entry fee.
7. Each puller shall be given two (2) free pit passes per pulling vehicle.
8. Each puller shall have on file with the Secretary a signed, notarized statement that his/her vehicle meets safety requirements for classes in which that vehicle will pull. This statement must be in the Secretary's possession **PRIOR TO THE PULLER'S FIRST HOOK. There will be NO EXCEPTIONS.**
9. Each vehicle may enter two (2) classes, but only once in each class. The Open Class is not included. Vehicles must weigh within 500 pounds of the class weight in which they are entered.
10. Proper clothing is required while on the pulling track. All pullers will wear a full firesuit with DOT approved helmet, fire shoes or leather boots. All helmets must be strapped on. Headsock & gloves are optional. It is recommended by the board that any vehicle using Methonal/Ethenol wear a SFI head sock and full face shield helmet.
11. When co-sanctioning with other associations and hooking in a MSTPA class all safety and fire suit protection must be **worn**. NO EXCEPTIONS !!!
12. No alcoholic beverages are to be consumed before hooking to the sled. Judges or board members governing the contest have the right to disqualify.
13. Vehicle speed is limited to six (6) miles per hour in the pit area.
14. No coaching from the sidelines is allowed while the driver is on the track.

15. Unsportsmanlike conduct will NOT be tolerated. Any verbal abuse by a puller or member of his/her party, toward a MSTPA official, MSTPA employee, MSTPA board member, to include sled personnel and persons maintaining the track and/or sponsor/promoter of a pull shall be cause for suspension of said puller & vehicle for a period of sixty (60) days from the date of occurrence.
16. Classes with cubic inch limits are subject to be checked at the Board's discretion. If a puller refuses to be checked, he/she will be disqualified for one (1) year & one (1) day.
17. If a puller is found illegal for weight, fuel or rule for their class, they will forfeit points & money for that pull. If a second offense occurs, he/she will be barred from competition for one (1) year & one (1) day & forfeit points & money for that pull. **Per board discretion.**
18. Pullers must register thirty (30) minutes prior to the start of the pull and pay the \$20 member hook fee or the \$50 one day membership fee. If puller calls the secretary/treasurer or president to sign them up outside extenuating circumstances this will result in a \$10 charge added to hook fee. Failure to sign up on time will result in a twenty dollar (\$20) fine per class, this will result in pulling in the 50% position of your said class or classes. Exceptions will be made when notifying a member of the board to advise of late arrival in the case of breakdowns or problems in transit to/from the pit.
19. At the time of registration, each puller will draw a number to determine the lineup position. If a puller is late in arriving at a pull, he/she must notify the Secretary or Treasurer 30 minutes prior to the start of the pull. If a puller is hooking in 2 classes, they must sign up for both 30 minutes prior to start time. Otherwise the late fee will be assessed.

If contestant needs to scratch from second class a refund will be issued. If you are late in arriving you will be fined the late fee per class pulled and pull in the 50% position of that said class. Exceptions listed above.

20. Each puller has the option to pre-commit in advance for hook fees. Your pulling position will be drawn for you by the person doing signups. If you are late and miss your class or pulling position you have forfeited your money for said pull. Refunds will only be issued by request in writing and after review by the board.
21. The lineup will be posted on the starting end of the track. It is each puller's responsibility to be ready when it is his/her turn. The next two (2) vehicles in the lineup following the one pulling must be ready to hook. Failure to be ready to hook in two (2) minutes after the sled is set will be cause for disqualification. It is the puller's responsibility to notify the track judge of trouble or be disqualified. The judge's decision as to mechanical trouble must be approved by a board member not pulling in the class being pulled and this decision will be final. Puller must return as soon as the mechanical problem is fixed. If a puller abuses this rule, he/she will be disqualified and prize money will NOT be awarded. Puller may receive three (3) hook points.
22. A chalker will be used to mark the "out of bounds" area with the inside of the line to be boundary.
23. Each puller has the privilege of and the responsibility for spotting the sled for both of his/her attempts. An orange cone will be used to mark the location where the sled is to be placed following departure of the previous puller from the starting line.
24. Vehicles must be driven on & off of the track under their own power only by the puller that is signed up

to drive that said vehicle if mechanically able, as determined by the driver.

25. Pulls will start with a tight hitch – no jerking permitted. Puller will be allowed two (2) attempts and one-hundred (100) feet to start the sled.
26. If the puller makes an attempt to stop before one-hundred (100) feet but travels past the mark, a repull will be allowed at the track judge's discretion.
 - a. First puller has the option to repull in 6th measured position; if the sled is reweighted puller can drop to 6th or last position.
 - b. If puller is the option hook and is disqualified they have the option to come back in the 6th measurable position.
27. If the puller's kill switch falls out on the first attempt, he/she will be allowed a second hook. However, if it falls out on the second attempt, the pull will be measured at that spot.
28. Vehicle will stop immediately upon signal by flagperson. Excessive digging will be not be allowed.
29. A pull is ended by the following:
 - a. Forward motion stops, and the sled chain is unhooked from the vehicle.
 - b. Disqualification – a puller is disqualified for any of the following reasons (i through viii) Puller shall receive only 3 hook points:
 - i. Driver does not remain seated.
 - ii. Vehicle goes outside the pulling strip, which includes the 100-foot starting strip.
 - iii. When a "floating" gate is used, this does not include the area beyond the gate measurement.
 - iv. Driver is not ready to pull when his/her number is called (exceeding the two-minute limit).

- v. Improper safety wear. Must wear the firesuit when pulling onto the track. Helmet must be on and strapped prior to start of pull.
 - vi. Pulling vehicle is left running on the track or staging area with no driver in the seat.
 - vii. Weights fall off of pulling vehicle while hooked to the sled. This is only in the first 300 feet.
 - viii. Riders on or in pulling vehicles.
- c. Disqualification – a puller is disqualified for consuming alcohol before pulling. The puller shall not receive any hook points.
- d. If driver whom signs up is not the driver that pulls down the track this will result in automatic disqualification and no points or prize money will be awarded to said vehicle or driver.
- e. All drivers must sign insurance waiver prior to hooking or disqualification is possible.
30. All pulls made during a contest will be measured. The point of measure will be the front center of the mechanical sled or the reflector for a laser.
31. If a “floating” gate is used, there will be no “out of bounds” past the 300-foot gate.
32. Puller must participate in at least 2/3 of the shows where the vehicle’s class is available to receive end-of-the-year awards and money. Prize money will be based on the percentage of total hooks in said class for the season being awarded.
33. There will be no “ties” in points awarded. If, at the end of the year, a point tie exists in a class, it will be broken by the puller who has the highest number of wins, 2nd, 3rd, etc.

34. There will be one jacket & one trophy or plaque awarded per pulling vehicle per class.
35. Any potentially new promoter or member that wishes to speak at the annual meeting may do so but is limited to two (2) minutes.
36. The use of recreational vehicles will be limited to the use of towing trucks or tractors in the pit area or for pulling purposes.
37. The use of head phones will be allowed.
38. All tractors (modified tractors are exception but need to have adequate board approved skid surface) must have front axle skid plates.
 - The skid plates must be mounted inline with each frame rail and extend from the center of the front axle forward (on both sides) equal in strength to frame rail material. Skid plate surface to be a minimum of 4" wide and 12" long with minimum 6" curve when measured from the front most part of rolled edge. The skid plate must be able to support the weight of the front end when checked with a jack. Maximum ground clearance is bottom of front wheel rim not to exceed 4 inches with front tires in normal operating position.
39. There will be a rotation of 3 MSTPA board members responsible at each pull who will stay until the end of the pull to make decisions as needed. These persons will also act as tech crew for that event.
40. All board members will have a radio on them at all times when a pull is in progress to be contacted if a problem arises or they are needed for a decision from track official, etc.

GENERAL SLED RULES

1. All sleds used must be **NASOA** licensed per classes offered at that event.
2. Race sleds will be used at all pulls.

PROTEST RULES

All rules pertaining to PROTESTER'S said class including but not limited to weight, hitch, tire size, carburetor, and turbo etc, can be protested for one-hundred fifty dollars (\$150) cash **BEFORE** the winners of the class are announced and the prize money is distributed. This money is non-refundable. The cubic inch rule can be protested at five-hundred dollars (\$500) cash.

CUBIC INCHES

The PROTESTER must pull in the same class as the vehicle being protested.

The PROTESTER must protest to the secretary/treasurer or board member in charge of the pull & post five-hundred dollars (\$500) cash **BEFORE** the winners of the class are announced & the prize money is distributed.

The PROTESTED must prove that his/her vehicle is legal to pull in that class by the following method:

- a. If protested for cubic inch, vehicle will first be puffed and if fails then step b is mandatory
- b. Mandatory Teardown. The cubic inch limited will not exceed the one percent (1%) tolerance.

If a protest is filed it will be the decision of the 3 board members on duty on how and where the protest will happen. The protester does not have the right to be at a cubic inch tear down. The board will notify the protester of the outcome and that is final.

If the vehicle cannot be checked the day of the protest, the vehicle will be impounded & put under lock & key at the nearest appropriate building until the check can be made.

If the PROTESTED refused or the vehicle is found to be illegal, the PROTESTED and the vehicle will be barred from competition for one (1) year and one (1) day, and the \$500 cash posted by the PROTESTER will be returned to the PROTESTER.

If PROTESTED proves his/her vehicle to be legal, he/she is awarded the \$500 cash posted by the PROTESTER and will continue in competition.

FUEL

The PROTESTER must pull in the same class as the vehicle being protested.

When protesting for fuel, the \$150 cash will be paid to MSTPA for the cost of testing. A fuel sample will be collected by a Board Member and tested.

If the report indicates an illegal substance, the PROTESTED and the vehicle will be barred from competition for one (1) year & one (1) day and forfeit points and money for that pull.

Neither the PROTESTOR nor the PROTESTED will receive any monies pertaining to a fuel protest.

Fuel testing may be done at the board's discretion. If a puller is found illegal for weight or fuel, he/she will forfeit points & money for that pull. If a second offense occurs, he/she will be barred from competition for one (1) year & one (1) day and forfeit points and money for that pull.

GENERAL VEHICLE RULES

1. Contest is limited to rubber-tired vehicles. No tire chains, rear duals with exception of diesel trucks or four wheel drive tractors are allowed.
2. All vehicles will have a tow hook in front to pull the vehicle when necessary.
3. All vehicles will have a 2 ½ pound fire extinguisher mounted within easy reach of the driver. A Halon fire extinguisher of equivalent size may be used.
4. All vehicles will have a strong seat, which will be inspected by a safety official.
5. All vehicles will have an area free of all obstructions immediately above the drawbar six (6) inches wide and 12 inches high.
6. Use of gravity-altering fuels is NOT allowed in all classes with exception of 6200 Prostreet 4x4. (e.g., oxygen, nitrous oxide, nitro methane, etc.)
7. All vehicle throttles, will push forward for “open” position & rearward for “idle” position. All throttle cables will be solid with no exposed cable. All vehicles will have a return-to-idle spring on the throttle.
8. Drawbars will be stationary in all directions. (See drawbars rules in the back of the **MSTPA Rule Book**).
9. Weights will not interfere with sled or chain.

10. All blower belts will be shielded on top & sides with 1/16 inch steel or 1/8 inch aluminum.
11. All blowers will have an approved blower restraint with four separate straps.
12. All vehicles with turbo & no muffler will have two (2) 3/8 inch bolts in the exhaust, as close to the elbow as possible at 90 degree angles, and no farther apart than two (2) inches.
13. All vehicles running cast iron harmonic balancers must shield them 360 degrees with 1/4 inch steel no more than one (1) inch away, with a minimum of two (2) ears each, extending one (1) inch in front of the hub. All others must have retainer tabs.
14. All vehicles will have an approved kill switch or air shut-off to be attached to the pulling sled without restraint and will be checked at the board's discretion.
15. All vehicles will have a working neutral safety switch to allow vehicles to start only in "neutral" or "park".
16. All vehicles, except Four-wheel Drive Trucks, will be equipped with "wheelie bars," to: (1) be constructed to conform to rules & chart in the back of the MSTPA Rule Book; or (2) use a five (5) inch by five (5) inch solid steel or aluminum roller mounted with a 3/4 inch grade eight (8) bolt that will not turn with the roller. It must be strong enough to support the weight of the vehicle.
17. All Two-wheel Drive Trucks & Modified Tractors with injected engines will have dual return-to-idle arms and springs on all injection and butterfly shafts.

18. All tractors will be equipped with individual workable, rear-wheel brakes.
19. All tractors, except 5900 Profield Tractors, will have wide front ends.
20. All tractors will have fenders which will support the weight of the driver and protect him/her from contact with the tires.
21. All tractors will be equipped with a five-point harness and have a "roll cage" to meet the requirements of the class.
22. All vehicles will have a back-up light, a minimum of two (2) inches in diameter, to be activated by the gearshift lever when the tractor is in "reverse".
23. All tractors must have a clutch blanket. Anything over 3000 RPM must have a steel fly wheel. Hot Farm Tractors under 3000 RPM can run blanket or steel band.
24. Tractors up to 6,000# will have a roll cage. Minimum of 2 bars, 90 thousands Chrome Moly or 120 thousands cold steel. All other Tractors over 6,000# must have a minimum of 3 bar cage 90 thousands Chrome Moly or 120 thousands cold steel.
25. All cages must be approved by the Board of Directors.
26. Contestants are not allowed to add fuel or change tire pressure after crossing the scales.
27. Only paid members in good standing with MSTPA may drive a self-propelled pulling vehicle to the scales.
28. All diesel tractors are required to have a 3 way dump valve.

5900 PROFIELD TRACTOR CLASS

All Vehicles Must Conform to “General Vehicle Rules”

1. Weight Class:
5900 lbs. – all tractors turbo and NA
3000 RPM limit with 1% tolerance
No RPM limit on NA tractors
NA gasoline tractors may run one (1) 4- barrel carburetor; will allow gas turbocharged motors with 361 cu in or less run 3500 rpm's - this will be evaluated after 3 pulls.
Allow gas turbocharged motors with 361 cu in or less to run mechanical fuel injection, NO electronic fuel injection.
18.4x38 max. tire size
A 361 cubic inch limit on turbo tractors
650 C.I. max. limit on NA tractors
Must run a minimum of 2 bar cage
Sheet metal needs to be in the family of the tractor
Any ag motor with like brand ag rear end

NO TOLERANCE WILL BE ALLOWED ON TIRE SIZE

2. All tractors will be equipped with a five-point harness and have a “roll cage”. (see General Rules section)
3. Tractors with tires other than sizes listed above will have their tires measured across the lugs with a tape measure to determine if they are legal.
4. Turbo and non-turbo tractors run in the same weight class.

5. Diesel powered tractors can run any injection pump. Maximum size of a P pump. No computerized injection systems.
6. Gas tractors may eliminate governors but must have ignition chip rev limiter and may run down draft carburetors but no predators allowed.
7. Water Injection is allowed.
8. Weights must be secured to the tractor, Rear weights must not be more than 3" maximum behind rear tires. Tractor length is not to exceed 13' from center of rear axle to farthest point forward including weights. Maximum of 6" tow-hook not include in 13' length.

9000 PROFIELD TRACTOR CLASS

All Vehicles Must Conform to “General Vehicle Rules”

1. Weight Class is 9000 lbs.
2. Tires will be no wider than 25” or 38” maximum inside diameter.
3. RPM limit is 3000 with one percent (1%) tolerance on the recheck.
4. RPM check will be done by two (2) board members with one checking the throttle while the other uses the tach.
5. Tractors will have a stock block with a cubic inch limit of 640.
6. Tractors may use “A” or “P” injection pump or stock-appearing pump.
7. Water injection is allowed.
8. Exhaust will have two (2) 3/8 inch bolts as close to the elbow as possible at 90 degree angles, no further than two (2) inches apart.
9. Hitch will be 18 inches in length and 20 inches high.
10. Tractors may use a turbo of choice with a standard restriction of 2.75 inches on the air inlet side of the turbo as close to the turbo as possible. The restriction will be readily accessible for a tech check.

11. Hot Farm Tractors in the 9000# Profield Tractor Class with a 2½ inch inlet on turbo and stock-appearing pump are allowed. There is a 500 pound weight allowance. To be reviewed after 3 pulls in order to pull in profiled class. No “P” pumps for the Hot Farm Tractors.
12. Only single-stage, exhaust-driven turbos will be allowed. Turbochargers must be under the hood or completely shrouded with not less than .060 thick steel, except for the inlet exhaust pipes.
13. Hot Farm Tractors having narrow front ends may pull in the Profield Class if all other requirements of the class are met.
14. All tractors will be equipped with a five-point harness and have a “roll cage” to meet the requirements of class. (see General Rules section)
15. No inner coolers or ice boxes are allowed.

9500 LIMITED PROSTOCK TRACTOR CLASS

All Vehicles Must Conform to “General Vehicle Rules”

1. Weight Class is 9500 lbs.
2. Tires will be no wider than 25” or 38” max inside diameter.
3. “P” Pumps & water injection allowed, no alcohol fuel
4. Exhaust will have two (2) 3/8 inch bolts as close to the elbow as possible at 90 degree angles, no further than two (2) inches apart.
5. Tractor may use a turbo of choice. Maximum of 4.1 at the inlet. No MWE groves to be allowed (smooth bore).
6. Must use steel fly wheel. Must have 6 strap clutch safety blankets and all safety equipment required as in the 9700 Profield Class.
7. Must have 3-way fuel shut off.
8. All tractors will be equipped with a five-point harness and have a “roll cage” to meet the requirements of class. (see General Rules section)
9. 9000 Profield Tractors may pull in the 9500 Limited Prostock Tractor class weighing 9700 lbs. but must follow rules for their 9000 Profield class.

10. Tractors will be allowed to run 640 cubic inches with no Billet heads. Recast or aftermarket heads will have port location same as stock and will have OEM manifold bolt pattern. (must be able to bolt on OEM manifolds)
11. No inner coolers or ice boxes are allowed.
12. Deck plates allowed up to .625 thick.
13. Allow superstock tractors to pull in the 9500 Limited Prostock class weighing 8600 lbs. This will be re-evaluated after 50% of hooks in 2012.

6200 PROSTOCK TRACTOR CLASS

All Vehicles Must Conform to “General Vehicle Rules”

1. Weight Class is 6200 lbs.
 - a. 361 and under run at 6200 lbs.
 - b. 362-385 run at 5700 lbs.

Any ag motor with like brand ag rear end.

2. Prostock Tractors & Superstock Tractors **share** the following rules. (Exceptions are listed on the following page):
 - a. Tractors will run steel, magnesium or aluminum flywheels that meet the following criteria:
 - i. Steel plate or steel billet flywheel will have a tensile strength of 60,000 psi and a yield strength of 40,000 psi.
 - ii. Magnesium or aluminum flywheels will meet SFI Spec. 1.1
 - iii. **POSTIVELY NO GRAY CAST IRON ALLOWED**
 - b. Tractors will have a **Spec. 4.1** approved blanket or a **SFI** approved clutch can.
 - c. Tractors will be operated having a hood and grill. Any ag motor with like brand ag rear end. Exhaust must be pointed upward. May run new sheet metal, but must have original rear end housing.

- d. Turbochargers not under the hood will be completely shrouded with steel .060 or thicker, except for inlet and exhaust pipes. Turbochargers under fiberglass hoods will be shrouded with .060 inch steel or thicker under the area of the fiberglass
- e. Tractors will be no longer than 13 feet from the center of the rear axle to the most forward position of the tractor, including weights.
- f. Tractors with no RPM limit will have T/A or power directors shielded with a steel shield or board-approved scatter blanket.
- g. Tractors will have a fire shield of .060 inch thick metal between the motor and driver extending from side shield and from top to bottom.
- h. All exposed drive trains will be shielded with 5/16 inch steel or 3/8 inch aluminum fastened every six (6) inches with 3/8 inch bolts, grade 5 or better, or butt-seam welded. Any additional manual transmission or gearboxes must be shielded in the same manner or be covered with a current SFI-approved scatter blanket secured as specified by SFI.
- i. Tractors will have side shields of .060 thick metal.
- j. All Superstock Tractor & Prostock Tractor engines will all have rotating masses mounted on the front of the crankshaft shielded 360 degrees from the front of the engine block to one (1) inch in front of the rotating mass. Shield will be of not less than .125 steel or aluminum and extend from frame rail to frame rail. Shield will be fastened to the frame on each side with a minimum of two (2) evenly

spaced 3/8 inch bolts, grade five (5) minimum. The remainder of the 360 degree shield will be of standard size and hood shielding. NOTE: The shield may be notched to allow the belt to pass through and beneath the frame to drive the fuel pump or oil pump, or it must shield them 360 degrees with 1/4 inch steel no more than one (1) inch away, with a minimum of two (2) ears each, extending one (1) inch in front of the hub. All others must have retainer tabs.

3. Legal Prostock Tractors can pull Superstock classes as an optional class.
4. **EXCEPTIONS (apply to ONLY Prostock Tractors):**
 - a. Limited to one (1) turbo
 - b. Limited to one (1) pump for diesel or one (1) carburetor for gas
 - c. Maximum tire size 24.5x32
 - d. No computerized fuel injection systems.
 - e. No Alcohol Allowed
 - f. Limit 2 valves per cylinder

6000 SUPERSTOCK TRACTOR CLASS

All Vehicles Must Conform to “General Vehicle Rules”

1. Weight Class:
 - 6000 lbs. – 360 cubic inch limit
 - 5700 lbs. – 361 cubic inch or larger
2. Tractors will be no longer than 13 feet from the center of the rear axle of the most forward position of the tractor, including weights
3. Maximum tire size is 30.5x32.
4. Tractors will be operated having a hood and grill. Any ag motor with like brand ag rear end. Exhaust must be pointed upward. May run new sheet metal, but must have original rear end housing.
5. Tractors will run steel, magnesium or aluminum flywheels that meet the following criteria:
 - a. Steel plate or steel billet flywheel will have a tensile strength of 60,000 psi and a yield strength of 40,000 psi.
 - b. Magnesium or aluminum flywheels will meet SFI Spec. 1.1
 - c. **POSTIVELY NO GRAY CAST IRON ALLOWED.**
6. The remainder of the 360 degree shield will be of standard side and hood shielding. All superstock

Tractors and Prostock Tractor engines will have all rotating masses mounted on the front of the crankshaft shielded 360 degrees from the front of the engine block to one (1) inch in front of the rotating mass. Shield will be of not less than .125 steel or aluminum and extend from frame to rail to frame rail. Shield will be fastened to the frame on each side with a minimum of two (2) evenly spaced 3/8 inch bolts, grade five (5) minimum.

NOTE: The shield may be notched to allow the belt to pass through and beneath the frame to drive the fuel pump or oil pump, or it must shield them 360 degrees with 1/4 inch steel no more than one (1) inch away, with a minimum of two (2) ears each, extending one (1) inch in front of the hub. All others, except Hot Farm Tractors, must have retainer tabs.

7. All tractors having air blowing through the throttle body, must run steel butterflies. **Aluminum is not allowed.**
8. Turbo chargers not under the hood will be completely shrouded with steel .060 inch steel or thicker, except for inlet and exhaust pipes. Turbochargers under fiberglass hoods will be shrouded with .060 inch steel or thicker under the area of the fiberglass.
9. Tractors with no RPM limit will have T/A or power directors shielded with a steel shield or SFI approved scatter blanket.
10. All exposed drive trains will be shielded with 5/16 inch steel or 3/8 inch aluminum fastened every six (6) inches with 3/8 inch bolts, grade 5 or better or butt-seam welded. Any additional manual transmission or gearboxes must be shielded in the

same manner or be covered with a SFI approved scatter blanket.

11. Tractors will have a fire shield of .060 inch thick metal between the motor and driver extending from side shield to side shield and from top to bottom.
12. Tractors will have side shields of .060 inch thick metal.
13. Tractors will have a SFI-approved blanket or SFI-approved clutch can.
14. Legal 6200 Prostock Tractors can pull in the 6000 Superstock classes as an optional class.

5900 & 7400 MODIFIED TRACTOR CLASS

All Vehicles Must Conform to “General Vehicle Rules”

1. Weight Classes are:
 - a. 5900 lb. class with weight:
 1. 6500 lbs. – single, naturally aspirated
 2. 6100 lbs. – twin, naturally aspirated and single forced induction
 3. 5900 lbs. – single aircraft or single industrial engine, twin forced induction or triple naturally aspirated.
 - b. 7400 lbs. class will weigh:
 1. 7900 lbs. – single, naturally aspirated
 2. 7600 lbs. – twin, naturally aspirated and single forced induction
 3. 7400 lbs. – single aircraft or single industrial engine, twin forced induction or four (4) naturally aspirated, three (3) blown wedge style heads not over 43% maximum of 871 blower, 1471 Hemi, 2 prochargers, or Superstock Tractor.
 4. 8000 lbs - Diesel superstock tractors. This will be evaluated by board after 3 hooks.
2. No portion of the tractor will exceed 14 feet forward of the centerline of the rear wheels.
3. Tractors will be equipped with a “dead man” throttle. Foot throttles will have a toe strap.
4. Tractors will have side shields of .060 inch metal extending four (4) inches above and four (4) inches below the crankshaft.

5. Exhaust will be pointed upward.
6. Tractors using an automatic transmission will be equipped with a reverse gear lockout.
7. Automotive type engines using clutches will be equipped with SFI approved clutch housing, pressure plate, flywheel and clutch disc. (Engines used by manufacturers in both automobiles and trucks are classed as “automotive”)
8. Automotive transmissions will be covered with a current SFI-approved scatter blanket and secured as specified by SFI.
9. The remaining drive train to the original tractor transmission, together with any multiple engine couplers, will be shielded 360 degrees with 5/16 inch minimum steel or 3/8 inch aluminum to be fastened every six (6) inches or less with a 3/8 inch bolts, grade five (5) or better to be butt-seam welded. Any additional manual transmission or gearboxes will be shielded in the same manner or be covered with a SFI-approved scatter blanket and secured as specified by SFI.
10. The following rules for **Turbine Engines** apply:
 - a. Any turbine engine that exceeds 8000 rpm on the output shaft will not be allowed to use a clutch/flywheel assembly, or an automatic transmission.
 - b. Exhaust pipes on turbines must extend a minimum of 6 inches above the top of the exhaust opening.
 - c. Exhaust stack diameter to be no smaller than 1 inch of the engine outlet.
 - d. No turbine engine will be operated beyond military temperature and rpm limits.

- e. Turbine air intakes must be screened with metal screen that has openings no larger than 3/16-in.
- f. Steel turbine engine containment shroud.
 - i. Engines under 1500 hp must have 3/8-inch steel shroud that surrounds the engine.
 - ii. Engines over 1500 hp must have a 1/2-inch steel shroud that surrounds the engine.
 - iii. The steel shroud must extend a min of 5 in. forward and 10 in. aft of the turbine section.
 - iv. The steel shroud must incorporate a minimum of 3/8-inch thick flanges that extend radially inward from the shroud on both ends of the shroud within a maximum of 1 inch of the engine casting.
 - v. A 1/2-inch gap between the engine and the ID of the flange must be maintained for air circulation inside the shroud.
 - vi. The flanges may be scalloped out to clear tubing, accessories, brackets, etc., and may be either rolled edges of the shroud or steel rings attached by welding or riveting to the shroud.
- g. Composite containment shroud system:
 - i. Because the T55 has multiple steel engine casings, the inner portion of the sandwich may be a minimum of .032-inch aluminum for the T55 only.
 - ii. If the sandwich containment is used the following specs will apply:
 - 1. T-53, T-58 and T-55 are required to have 25 layers of Kevlar 29, 328 or 713 weave or current replacement number.
 - 2. T-64 and JFTD-12 are required to have 40 layers of Kevlar 29, 328 or 713 weave or current replacement number.

- iii. Numerous bolts inserted through the three segments (the two metal sheets and the Kevlar) of the sandwich are required.
- iv. An air gap of 1/2-inch must be maintained for air circulation between the engine outer casing and the sandwich.
- v. End flanges that are required for the steel containment shroud are not required when using the Kevlar sandwich.
- h. Two independent overspeed protection devices are required for power turbine wheel(s).
- i. The governor setting must not exceed manufacturer's maximum specifications.
- j. Overspeed shutdown – consists of speed monitor that activates a normally closed solenoid valve located between fuel control and fuel manifold. Trip setting to be low enough to prevent overspeed in event of driveline failure.
- k. No homemade turbine engines allowed as competition engines.
- l. No Lycoming T-55-L-11 or TF-35 engines allowed as competition engines.
- m. Tech inspection at pull to include a function test of the shutdown solenoid without starting the engine.
- n. Turbine engines may start in gear only while hooked to the sled.
- o. Turbine vehicles allowed starter motor onboard, or auxiliary power unit to be carried onboard and running during a competition attempt, but must not be hooked into the drive train during competition attempt.

6200 TWO-WHEEL DRIVE TRUCK CLASS

All Vehicles Must Conform to “General Vehicle Rules”

1. Weight Classes is 6200 lbs:
 - a. One (1) Naturally aspirated, automotive type engine
 - b. 541 cubic inch limit with no tolerance
2. Trucks will be no longer than 15½ feet from the center of the rear axle to the most forward position of the truck, but no weight further than 15 feet.
3. Maximum tire size is 18.4x16.1
4. Trucks will have a presentable bed or flat.
5. Trucks newer than 1940 will have hoods and fenders in place. All side doors will be in place.
6. Trucks will run steel, magnesium or aluminum flywheels that meet the following criteria:
 - a. Steel plate or steel billet flywheel will have a tensile strength of 60,000 psi and a yield strength of 40,000 psi.
 - b. Magnesium or aluminum flywheels will meet SFI Spec. 1.1
 - c. **POSITIVELY NO GRAY CAST IRON ALLOWED.**

7. Use of aluminum blocks or sheet metal manifolds will **NOT** be allowed. Allow the use of conventional style aluminum heads. No hemi, no billet. Only modification allowed is porting. No external modifications. Only 2 valves per cylinder. Must have factory OEM port design – i.e. Ford 429 CJ, Chevrolet rectangle port. OEM meaning used in passenger car.
8. Each driveshaft will have a minimum of two (2) steel loops 1/8 inch thick, 1 inch wide, 6 inches (maximum) above and below. If a vehicle has a shaft between the transmission and transfer case no longer than 24 inches, one (1) loop, properly centered, will suffice. Two-piece shafts will have four (4) loops. Planetary drivelines will be shielded 360 degrees with 3/16 inch steel or 3/8 inch aluminum.
9. All driveline u-joints will be enclosed 360 degrees with 1/16 inch steel or 1/8 inch aluminum. Shield will be close enough to the joint to restrain any broken parts. Joint will not be visible from the side, top or bottom.
10. Trucks with engine-driven fan blades will have a fan shroud extending 360 degrees around the blade to be constructed of 1/16 inch minimum steel. Shroud will be no more than one (1) inch from the radiator core at least ¼ inch past the rear blade.
11. Trucks will be equipped with steel bellhousing and blocksaver plate.
12. Automotive transmissions will be covered with a SFI-approved scatter blanket and secured as specified by SFI.
13. Exhaust will discharge vertically or underneath and straight back.

14. If the battery is inside the cab, it will be safely enclosed and securely fastened down.
15. Braking system will be an adequate, foot-operated hydraulic system.
16. Radiator hoses or water hoses will **NOT** be allowed in the driver's compartment
17. Axle bolts will be covered securely with a 1/16 inch metal shield.
18. Kill switch will be located in the rear of the truck bed and be unrestrained.
19. Weights will not extend farther back than 12 inches from the hitching point.
20. Maximum hitch height is 30 inches and no closer than 18 inches from center of rear axle. At 10 degree or less of drawbar angle. (See drawbar rules)
21. Trucks will have "wheelie bars" which will extend two (2) inches back from the farthest point of the tire, with a five (5) inch square pad on the bottom or a 5x5" solid steel or aluminum roller mounted with a 3/4" grade 8 bolt that will not turn with the roller. This device must be able to support the weight of the vehicle. The bottom of the front tire will not exceed 40 inches above the ground at the highest point.
22. Driver will wear seat belt while pulling.

6200 PROSTREET 4X4 TRUCK CLASS

All Vehicles Must Conform to “General Vehicle Rules”

1. Weight Classes are:
 - a. Naturally aspirated engines **ONLY**
 - b. 473 cubic inch limit
2. Tires will be DOT approved and must maintain original tread pattern. Maximum tire size is 33x12.50. **NO BARRED TIRES.**
3. Vehicles will have stock-appearing frame and body. Fiberglass bodies are allowed. Bed with wood or steel floor will be securely fastened to the frame. Bed may be cut out as long as it is covered. **NO** holes in the hood. **NO** body lifts. Hood scoops are allowed, but **CANNOT** be functional.
4. Vehicle will maintain stock wheelbase maximum of 133”, one ton maximum front end with the use of any rear end.
5. Vehicle will be limited to one (1) carburetor. Dominators are allowed.
6. Vehicle will run fuel designated for make of truck. **NO** alcohol.
7. Use of aftermarket fuel injection systems is **NOT ALLOWED.**

8. Trucks will run steel, magnesium or aluminum flywheels that meet the following criteria:
 - a. Steel plate or steel billet flywheel will have a tensile strength of 60,000 psi and a yield strength of 40,000 psi.
 - b. Magnesium or aluminum flywheels will meet or exceed former SEMA standards 1-1.
 - c. **POSTIVELY NO GRAY CAST IRON ALLOWED.**
9. Vehicle will be equipped with SFI-approved bell housing and block-saver plate. Must have shield around the clutch release hole.
10. Vehicle will have O.E.M. transfer case.
11. Vehicle will have O.E.M. cast iron heads and any cast iron blocks. No sheet metal intake manifolds. Use of aluminum heads or Hemi-heads will **NOT** be allowed. Engine location must be no less than 14" from center line of front axles of bell housing flange.
12. Automatic transmissions will have a SFI-approved blanket or shield.
13. Vehicle may run open headers turning back instead of down.
14. All u-joints must be covered 360 degrees with 1/8 inch steel or 3/16 inch aluminum having two (2) steel driveshaft hangers per driveshaft, 1/8 inch thick, 1 inch wide, 6 inches (maximum) above and below. All drive shafts shorter than 24" require one (1) hanger.
15. Vehicle may have solid rear suspension.

16. Vehicle will have factory front bumper. Bumper must be bolted in stock location. Weights will not extend beyond the front bumper.
17. Rear hitch location will be no closer than 36% of the wheelbase to the center of the rear axle and no more than 26 inches in height.
18. Kill switch will be located in the rear center of the truck bed with out restraint.
19. Driver will wear seat belt.
20. May hook in the 6200 Prostock 4x4 class if the 6200 Prostreet is not offered, this will not be counted for points. Puller and vehicle must be a member and have a registered vehicle.

6200 PROSTOCK 4X4 TRUCK CLASS

All Vehicles Must Conform to “General Vehicle Rules”

1. Weight Classes is 6200 lbs.:
 - a. Naturally aspirated engines **ONLY**
 - b. 485 cubic inch limit
 - c. Engine will be same make as vehicle
2. Tires will be DOT approved and must maintain original tread pattern. Maximum tire size is 33x12.50. Tires will not track past 50% of front to rear width. **NO BARRED TIRES.**
3. Vehicle will have stock frame. Air bag suspension is not to be controlled from inside the cab.
4. Vehicle will have a 133” maximum stock wheelbase, any body style – including fiberglass with a protective fire wall, one ton maximum front end, any size rear end. No flat bed.
5. Vehicle will be limited to a single “1 piece” carburetor.
6. No alcohol fuel allowed. Q-16 Fuel is allowed.
7. Use of after-market fuel injection systems is **NOT** allowed.
8. Vehicle will be equipped with SFI steel bellhousing and block-saver plate. Must have shield around the clutch release hole.

9. Vehicle may run any transfer case.
10. Vehicle may use any cast iron block not exceeding 4.9 bore spacing. No aluminum blocks. Any after-market head having no more than two (2) valves per cylinder may be used. No hemi-heads. No sheet metal manifolds and no two-pieced or removable top tunnel rams.
 - a. Engine location must be no less than 14" from center line of front axle to front of bell housing flange.
11. Allow functional hood scoops with open back. Hood perforations will be allowed for exhaust only.
12. Exhaust will discharge vertically or underneath and straight back.
13. Trucks will run steel, magnesium or aluminum flywheels that meet the following criteria:
 - a. Steel plate or steel billet flywheel will have a tensile strength of 60,000 psi and a yield strength of 40,000 psi.
 - b. Magnesium or aluminum flywheels will meet or exceed former SFI standards 1.1.
 - c. **POSTIVELY NO GRAY CAST IRON ALLOWED.**
14. All u-joints must be covered 360 degrees with 1/8 inch steel or 3/16 inch aluminum having two (2) driveshaft hangers per driveshaft 1/8 inch thick steel or 3/16 inch aluminum 1 inch wide, six (6) inches (maximum) above and below shaft.
15. All drive shafts shorter than 24 inches require one (1) hanger.
16. Automatic transmissions will have a SFI-approved blanket or shield.

17. The leading edge of the front weights will not extend more than 60 inches in front of the axle centerline.
18. Rear hitch location will be no closer than 36% of the wheelbase from the center of the rear axle and no more than 26 inches in height. There will be no "L" type hitches or "Camtype" hitches. Hitch angle will be: from point of hook to centerline of point of pull, no part of the angle of the stem (pole) will exceed 25 degrees.
19. Kill switch will be located in the rear of the truck bed without restraint.
20. Driver will wear seat belt.
21. The 6200 Prostreet 4x4 trucks will be allowed to hook in this class if the 6200 Prostreet is not offered, this will not be counted for points. Puller and vehicle must be a member and have a registered vehicle.
22. No electronic traction control devices allowed.

8000 Diesel 4x4 Truck Class

All Vehicles Must Conform to “General Vehicle Rules”

1. Weight will be 8000.
2. Weights must be secure and may not extend more than 60 inches from the centerline of the front axle. Weights may be fastened in the rear bed, but are not allowed in the cab of the truck. No tarp straps allowed for any purpose.
3. No passengers allowed
4. Seat belts are required and must be worn while truck is on the track and drivers side window must be down.
5. Interior seats may be removed except for the drivers seat
6. No fuel tanks allowed inside the cab
7. All trucks must be weighted and certified, underhood inspection will be made at that time.
8. Trucks must be safe operating condition
9. The frame and wheelbase, MUST be the OEM for that truck. NO Flatbeds. The body must retain full sheet metal floor. If the truck has been gutted, 200lbs of movable weight must be placed rearward of the centerline of the rear axle.

10. Adequate brakes are mandatory.
11. The engine must be in the OEM stock location. Maximum of 460 cu in. Engines may be changed to cross factory lines of manufacturing, (cummins may be put in Ford or Chevy) Factory option engines for 1 ton trucks and lighter are only allowed. No aftermarket blocks
12. Aftermarket transmission and transfer case are allowed
13. Dual rear wheels are allowed.
14. Rear suspension may be welded
15. Traction and ladder bars are allowed.
16. All front axles must have coil or leaf springs and must be in stock location. Adjustable front suspension stops must be mechanical. Pneumatic, hydraulic, and electrical adjustable stops are not allowed.
17. The tires must be DOT street tires. No altered, cut, or recap tires allowed. Maximum diameter is 35".
18. Hitch height shall be a maximum of 26". No transfer type hitches allowed. Receivers must be made of solid steel with an oblong shaped hole 3 3/4" long and 3" wide. Hitch must be frame mounted behind the rear axle of vehicle. No pulling point above truck frame rails with 44" minimum from center of rear axle to hook point. Rear bumper bars are required.
19. **Turbocharger:** The vehicle is limited to a 2.6 inducer bore single turbocharger. The compressor wheel must protrude into a 2.6" bore for 1/8". The inlet will be measured using a 2.65" plug and plug must not be able to enter inducer bore. AS stock

map width enhancement (MWE) groove is allowed. No MWE groove will be allowed that has a width greater than .200". All provisions allowing air into the wheel other than via the bore and MWE groove are prohibited. The vehicle driver will be responsible for making compressor wheel accessible for tech personnel to measure bore and able to inspect compressor wheel." The class discussed this rule and was dead locked and didn't want to kick anyone out. The board asked them to go to the back of the room and talk to each other and work something out. After the general rules meeting the class came to the board and presented their proposal. Their proposal is to allow both 2.6 and 3.0 in the same class. All will have 26" hitch – 2.6 turbos will run at 8000# and 3.0 will run at 7500#. Any 2.8 will run at 7500# also. This is to be re-evaluated after first 3 events. For each of the first 3 events all members will receive 10 points for hooking in the class and prize money will be split equally amongst all entered into the class.

20. Aftermarket computer chips and auxiliary boxes are allowed.
21. Water injection (only) is allowed. Alcohol, methanol, propane, Nitrous Oxide and all oxygen extenders are prohibited.
22. The fuel injection pump is limited to any P series injection pump one plunger per cylinder.
23. All trucks must have a three way dump valve (manual) ahead of the injection pump to be operated from the dash panel and must be equipped with a functioning air shut-off. That is operated from the rear of the vehicle. The air shut-off switch must have a 2" ring and be mounted directly above the hitch in the center of the tailgate area.

24. Drive shaft Loops: All trucks must have three round metal loops shielding on each driveshaft (two piece driveshaft will have six metal loops). 360 degree loop must be constructed of at least 5/16 inch steel or 3/8 inch aluminum, 3/4" wide or wider and not more than 2" from the shaft in any direction. End loops to be placed no further than 6" from universal joints, with third loop in center of shaft, or can be a solid tube (3/8" aluminum or 5/16" steel) meeting the above requirements.
25. All trucks will have 360 degree metal shields around the universal joints, 3/8" thick aluminum with 1/8" steel insert or 1/2" aluminum or 5/16" steel. Minimum width 6". The insert must be a minimum of 6" wide. Shield must have a minimum of 2" clearance and a maximum of 4" clearance.
26. Exhaust: may exit thru hood of vehicle and must point upward Two 3/8 inch diameter bolts minimum grade 5 must be placed through the exhaust pipe, 90 degrees from each other, within one inch of each other as close to the turbo as possible.
27. All vehicles are required to have an SFI approved clutch, and flywheel, An SFI approved scatter blanket(s) is required around the bellhousing or SFI approved clutch can.
28. Axle and hub bolt shields required to be minimum of .060" thick. Minimum diameter of axle end and hub bolts to be covered on both front and rear axles. Mounting shield cannot be mounted to axle end or hub bolts. A hole may be installed in the center of front shield so that lock can be operated, so long as hub end or axle bolts are covered.

OPEN CLASS

(NO POINTS AWARDED)

All Vehicles Must Conform to “General Vehicle Rules”

1. Any vehicle that complies with the “General Rules,” “General Vehicles Rules” & “Open Class” rules may pull in this class.
2. Drawbar height will not exceed.
 - a. Tractors – 20 inches
 - b. Two-wheel Drive Trucks **with** blower or turbo – 26 inches
 - c. Two-wheel Drive Trucks **without** blower or turbo – 30 inches
 - d. Prostock Trucks – 27 inches (may change to barred tires if desired)
 - e. Superstock & Modified Four-wheel Drive Trucks – 26 inches

Two-Wheel Drive Truck	6200 lbs.
Blower Two-Wheel Drive Truck	6200 lbs.
Prostreet 4x4 Truck	6200 lbs.
Prostock 4x4 Truck	6200 lbs.
Modified & Superstock 4x4 Truck	6200 lbs.
Profield Tractor	10500 lbs.
Single Blown Modified Tractor	7600 lbs.
All Other Modified Tractors	7200 lbs.
Superstock/6200# Prostock Tractors	6500 lbs.
8700 Prostock Tractors	9500 lbs.
ULSS 20 inch drawbar	7200lbs
Alcohol with aluminum head	7700 lbs.
DSS 20 inch drawbar	8200 lbs.
PS 20 inch drawbar	8500 lbs.
LPS 20 inch drawbar	9600 lbs.
SF 20 inch drawbar	9800 lbs.

ASS 20 inch drawbar
Alcohol with cast iron head 8000 lbs.
Two-Wheel Drive 30 inch drawbar
Naturally aspirated

To Be Reassessed After 3 Shows By The Board of Directors.

Abbreviations

2WD	–	Modified 2WD Trucks
4WD	–	Modified 4WD Trucks
6SS	–	Light Super Stock Tractors
DSS	–	Diesel Super Stock Tractors
MOD	–	Modified Tractors
P4X4	–	Pro Stock 4x4 Trucks
PS	–	Pro Stock Tractors
DB	–	Draw Bar
SF	–	Super Farm
LPS	–	Limited Pro Stock
ASS	–	Alcohol Super Stock

DRAWBAR RULES

1. Drawbars cannot be shorter or higher than specifications listed below. Drawbar lengths are measured from the center of the rear wheels to the point of the hook.

Class	Drawbar Height	Min. drawbar length from center line of rear axle
Tractors	20"	18"
2WD	30"	18"
4WD	26"	36 percent
Pro Street 4x4	26"	36 percent

2. Drawbars must be rigid in all directions, no movement allowed. Drawbars must have the pivot pin on the same plane as the hitch point and parallel to the ground with in 1 1/2 inches, plus or minus, per foot of length. This formula translates to a legally allowed 10 degree or less of drawbar angle. All drawbars must be parallel to the ground with the exception of 4WD trucks.
3. All truck and tractor classes up to 8200 lbs., regardless of division, must meet the following requirements: drawbar to be a minimum of 2 sq. inches total material (steel) at any point. This will include the area of the pin with the pin removed. Any pin will be minimum of 7/8". Drawbar must be equipped with a steel hitching device not more than 1 1/2" x 1 1/2" square (1 1/2" round stock); and with an oblong shaped hole 3 3/4" long and 3" wide with a tolerance of + or - of 1/8 of an inch.
4. No portion of the vehicle may interfere with sled, chain or hook during a pull or while being hooked or unhooked.

5. An area 5" wide and 12" high immediately above and below the drawbar must be free of all obstructions (including weights, stabilizer bars, and second drawbars) for ease of hooking and unhooking.
6. Vehicles with second drawbars must have their primary drawbar 8" above the second drawbar. Hole in second drawbar must be covered if not in use.
7. Drawbars and wheelie bars are not to be connected.
8. No trick hitches, or cam type rear ends. Drawbar height or distance from center of rear axle cannot change during the pull. Drawbar must be rigid in all directions. All rear ends will be bolted or welded to frame to prevent any movement.
9. The competing vehicle will not be tied down to the tow vehicle through or on the drawbar in any way while in transport.
10. No L-shaped drawbars will be permitted in any division.

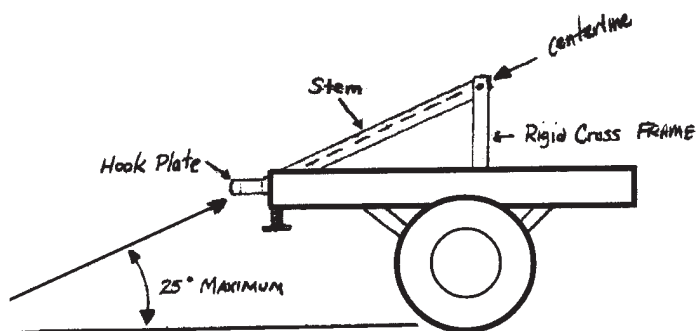

*This is one example of a 25 degree hitch angle.
Your hitch construction does not have to look
exactly like this one.*

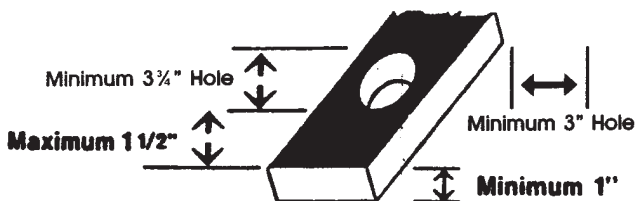

HOOK MUST FREE FALL

STABILIZER BAR

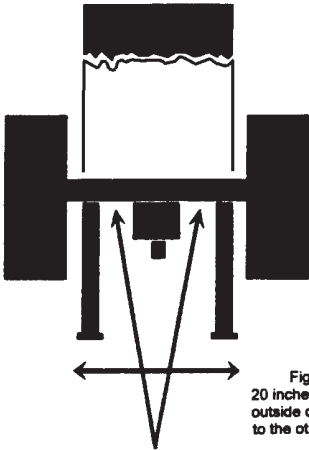
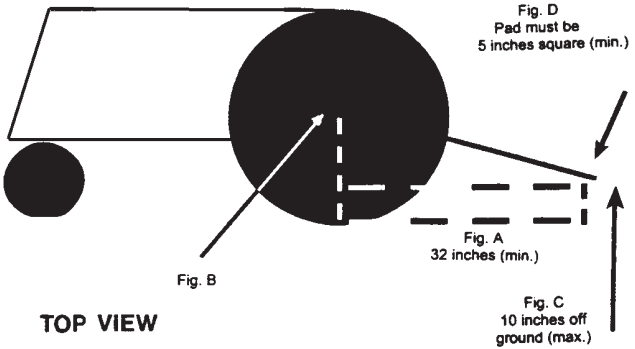

The stabilizer bar will extend a minimum of 32 inches behind a line (Fig. A) drawn from the center of the wheel (Fig. B) to the ground. The stabilizer pad must be no more than 10 inches off the ground (Fig. C). The stabilizer pad must be a minimum of five inches square (Fig. D). A minimum of 20 inches will be allowed from the outside of one pad to the other (Fig. E). Stabilizer bars are not to be mounted in any way to the drawbar.

NOTE: The stabilizer bar system must be able to support the weight of the tractor in the heaviest class pulled. Jacking up the pads so tractor is completely off the ground is a good test.

The stabilizer bars and their assembly are in no way to be connected to the drawbar or its assembly.

NOTES

NOTES

inside back cover blank

MISSOURI STATE

WFSU

TRACTOR PULLERS

ASSOC.